

Service Schematics

NOKIA 1110/1600 1112

Exploded view and component disposal

Introduction

Important:

This document is intended for use by authorized service centers only.

“Service Schematics“ was created with focus on customer care.

The purpose of this document is to provide further technical repair information for NOKIA mobile phones on Level 3/4 service activities.

It contains additional information such as e.g. “Component finder”, “Frequency band table” or “Antenna switch table”.

The “Signal overview” page gives a good and fast overview about the most important signals and voltages on board.

Saving process time and improving the repair quality is the aim of this document.

It is to be used additionally to the service manual and other training or service information such as Service Bulletins.

All measurements were made using following equipment:

Nokia repair SW	:	Phoenix version 2006.04.6.130
Oscilloscope	:	Fluke PM 3380A/B
Spectrum Analyzer	:	Advanced R3162 with an analog probe
RF-Generator/GSM Tester	:	Rhode & Schwarz CMU 200
Multimeter	:	Fluke 73 Series II

While every endeavour has been made to ensure the accuracy of this document, some errors may exist. If the reader finds any errors, NOKIA shall be notified in writing.

Please send E-Mail to: training.sace@nokia.com

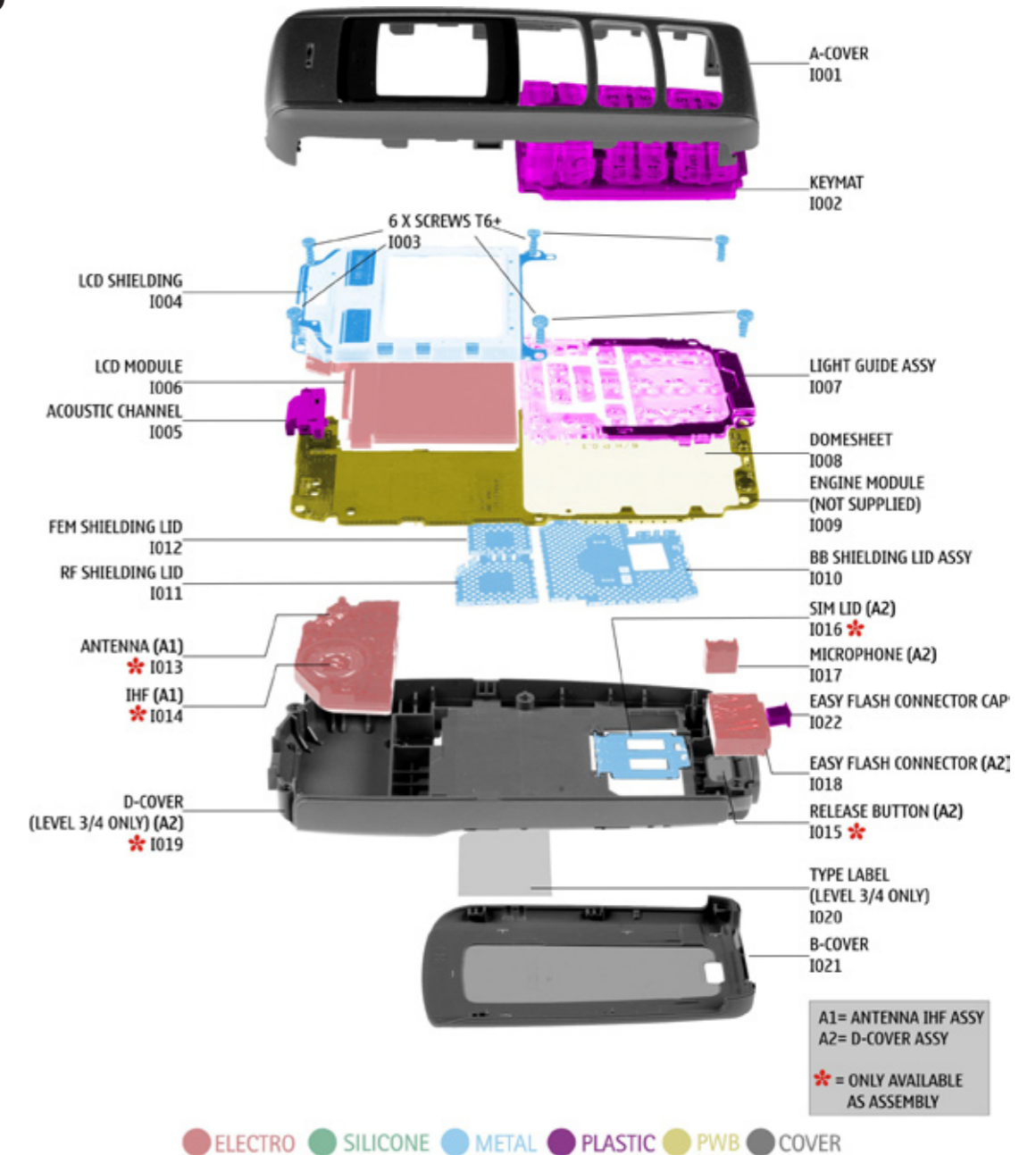
Copyright © NOKIA

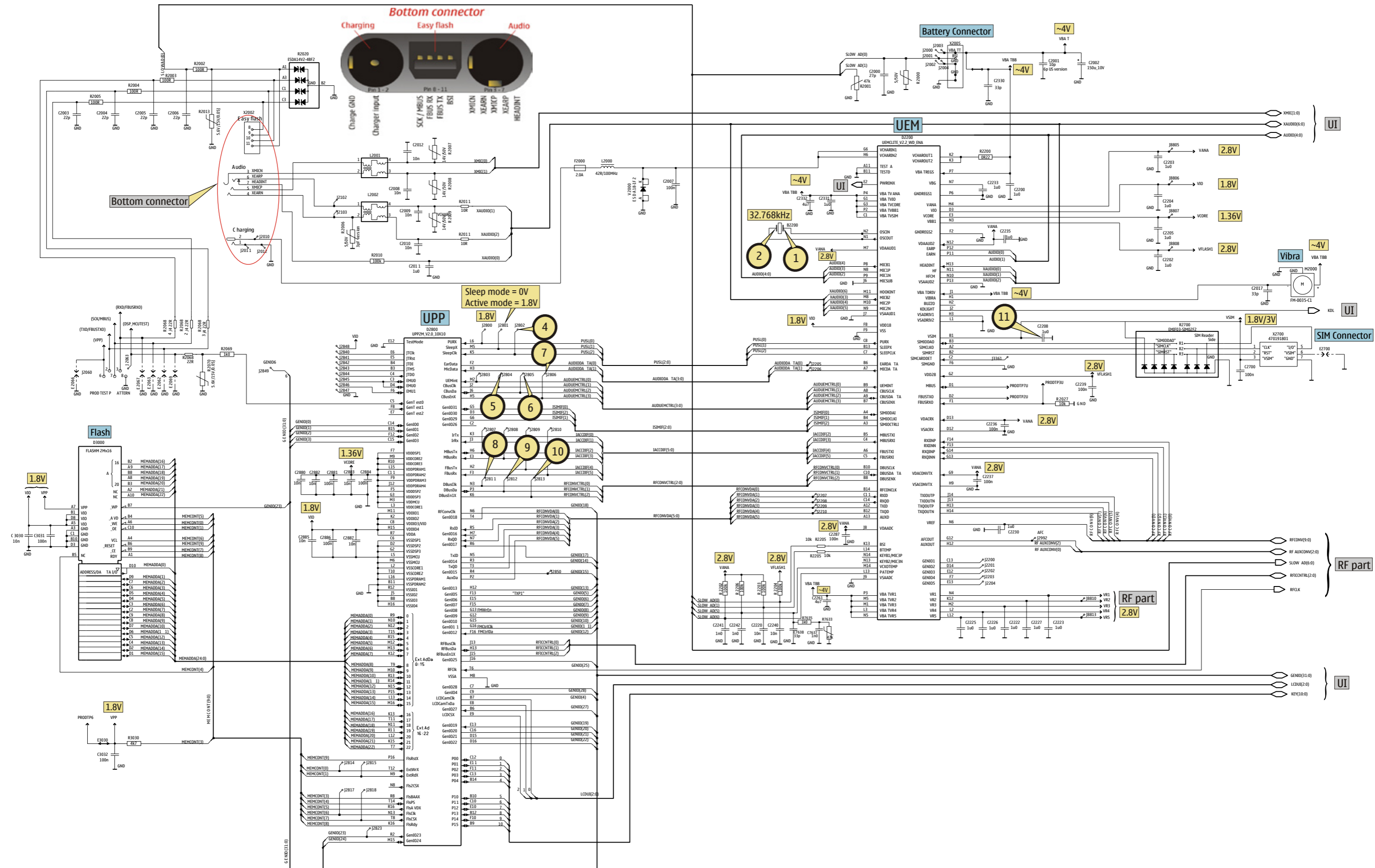
This material, including documentation and any related computer programs is protected by copyright, controlled by NOKIA. All rights are reserved. Copying, including reproducing, modifying, storing, adapting or translating any or all of this material requires the prior written consent of NOKIA. This material also contains confidential information, which may not be disclosed to others without the prior written consent of NOKIA.

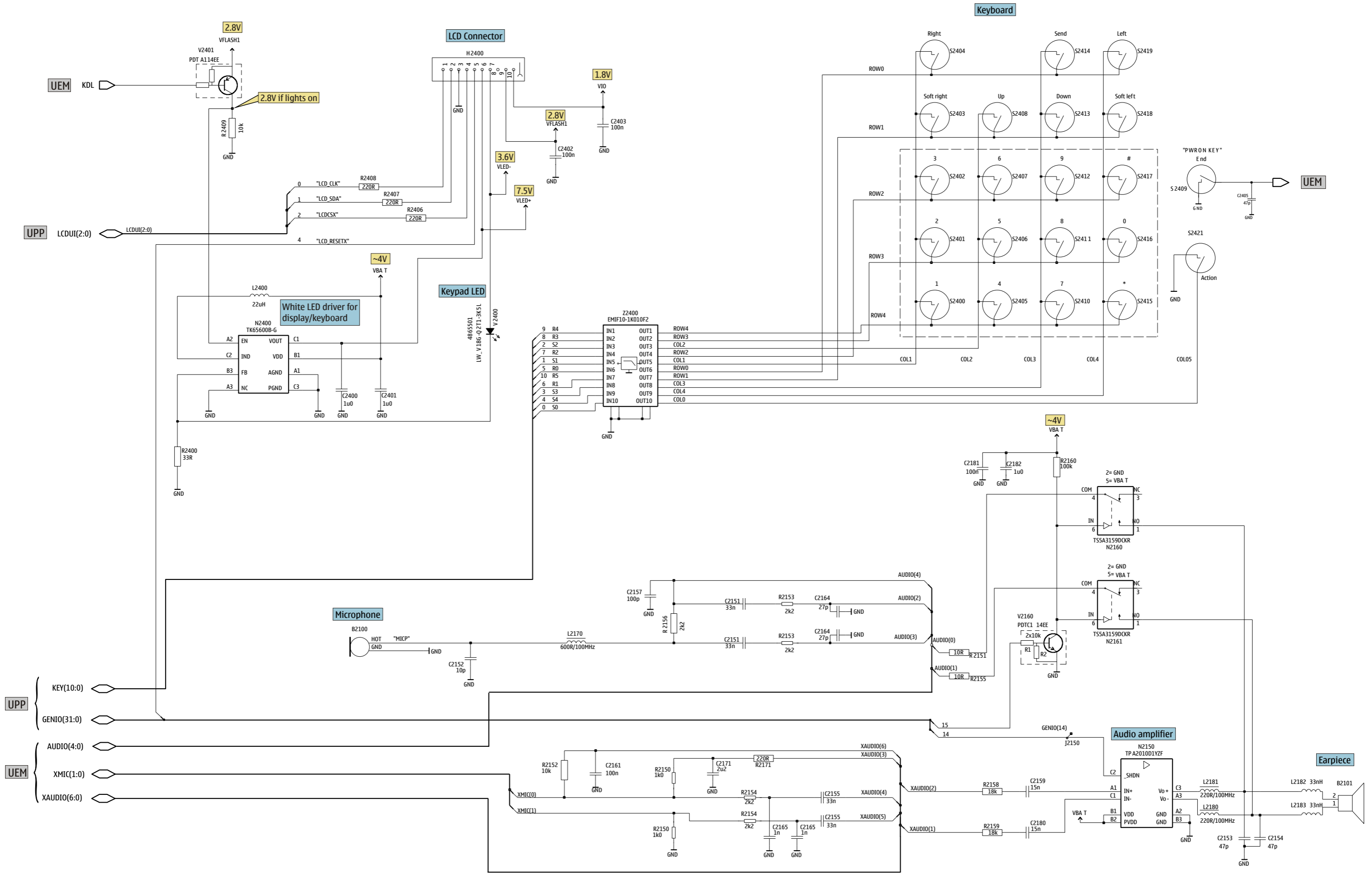
RH-69/70 / RH-64/65 RH-92/93

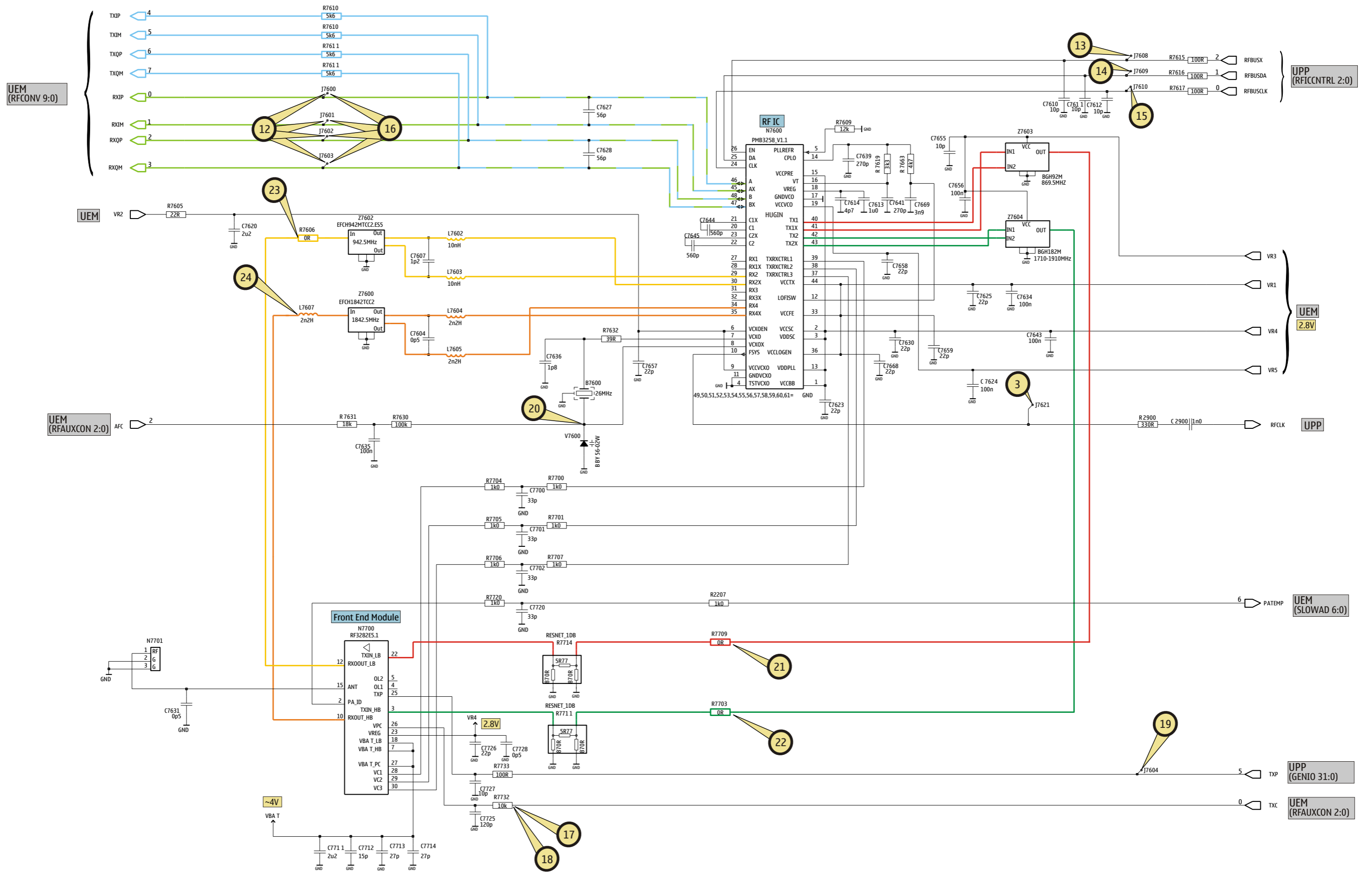


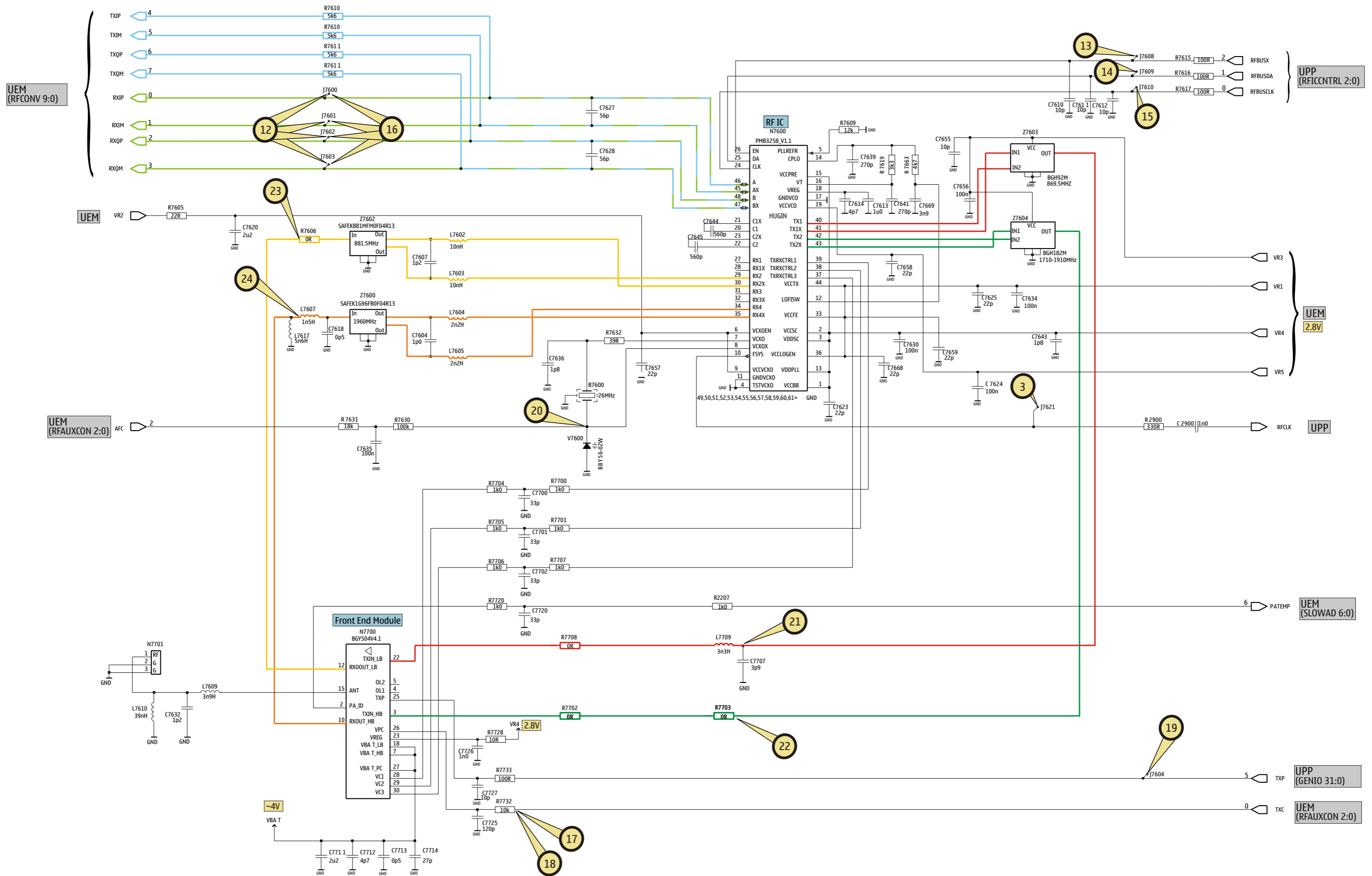
Table of contents	
Frontpage	1
UPP, UEM, Flash & SIM	2
UI & Audio	3
RF part - EU	4
RF part - US	5
Signal overview	6
Component finder - EU	7
Component finder - US	8

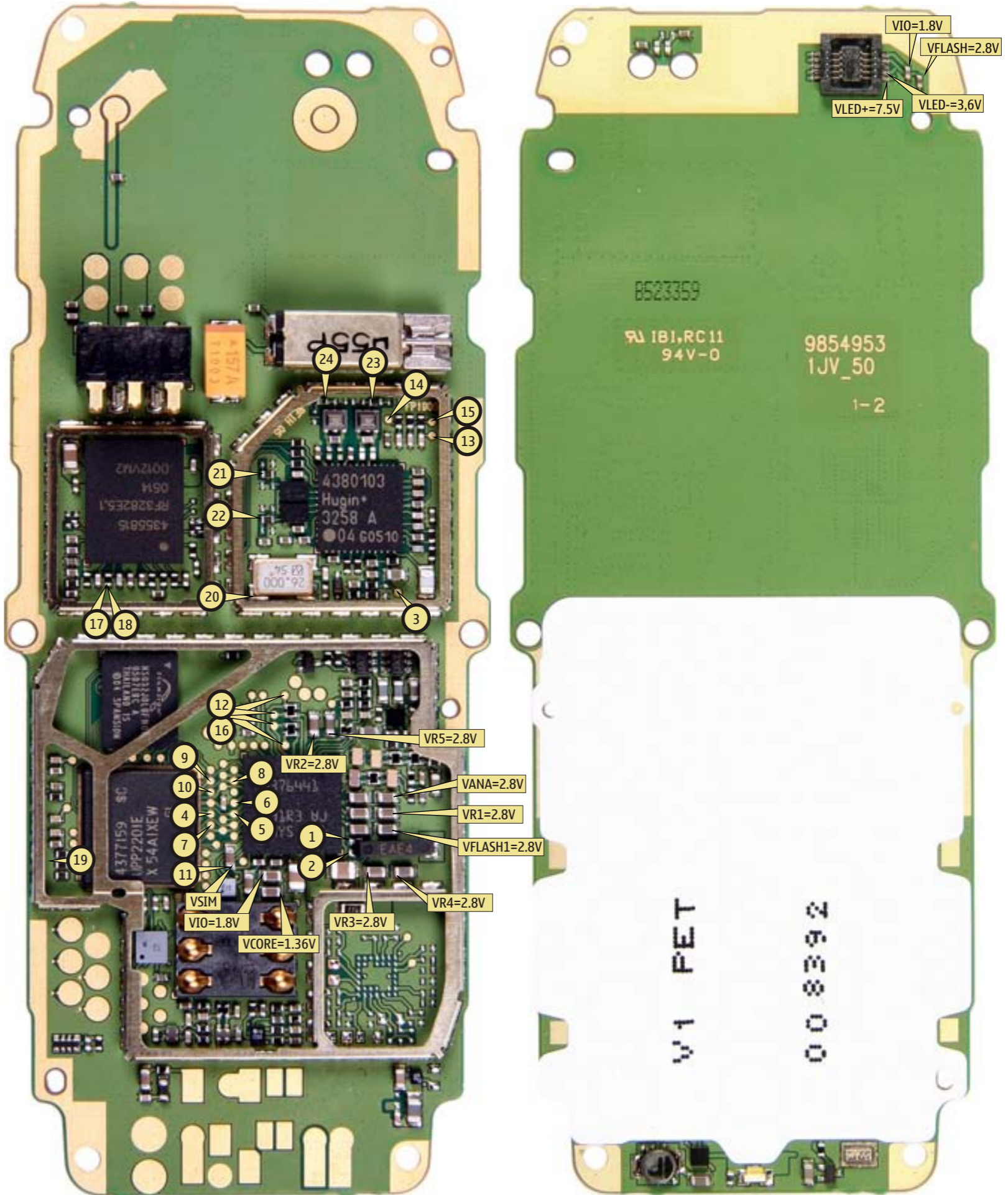
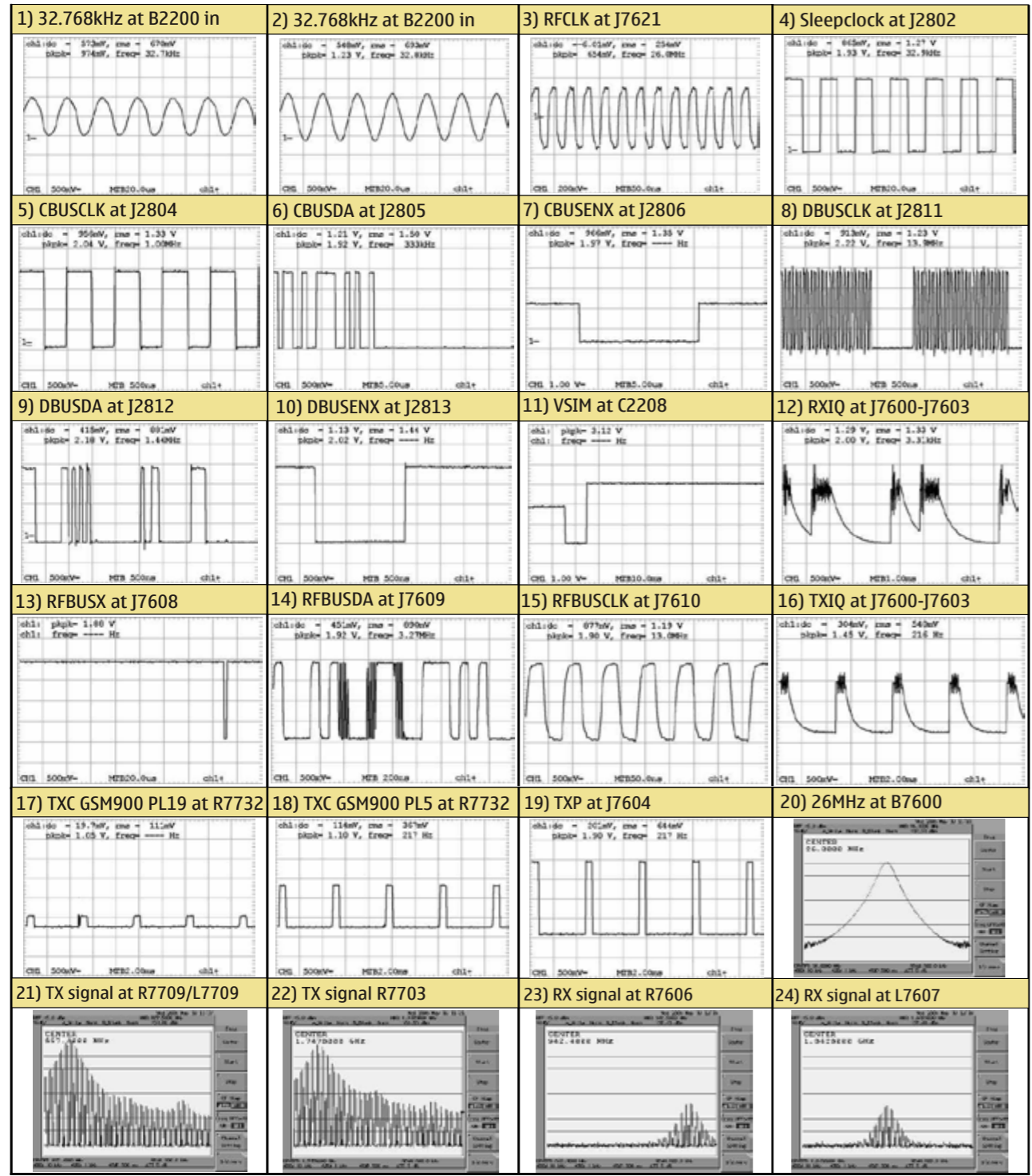




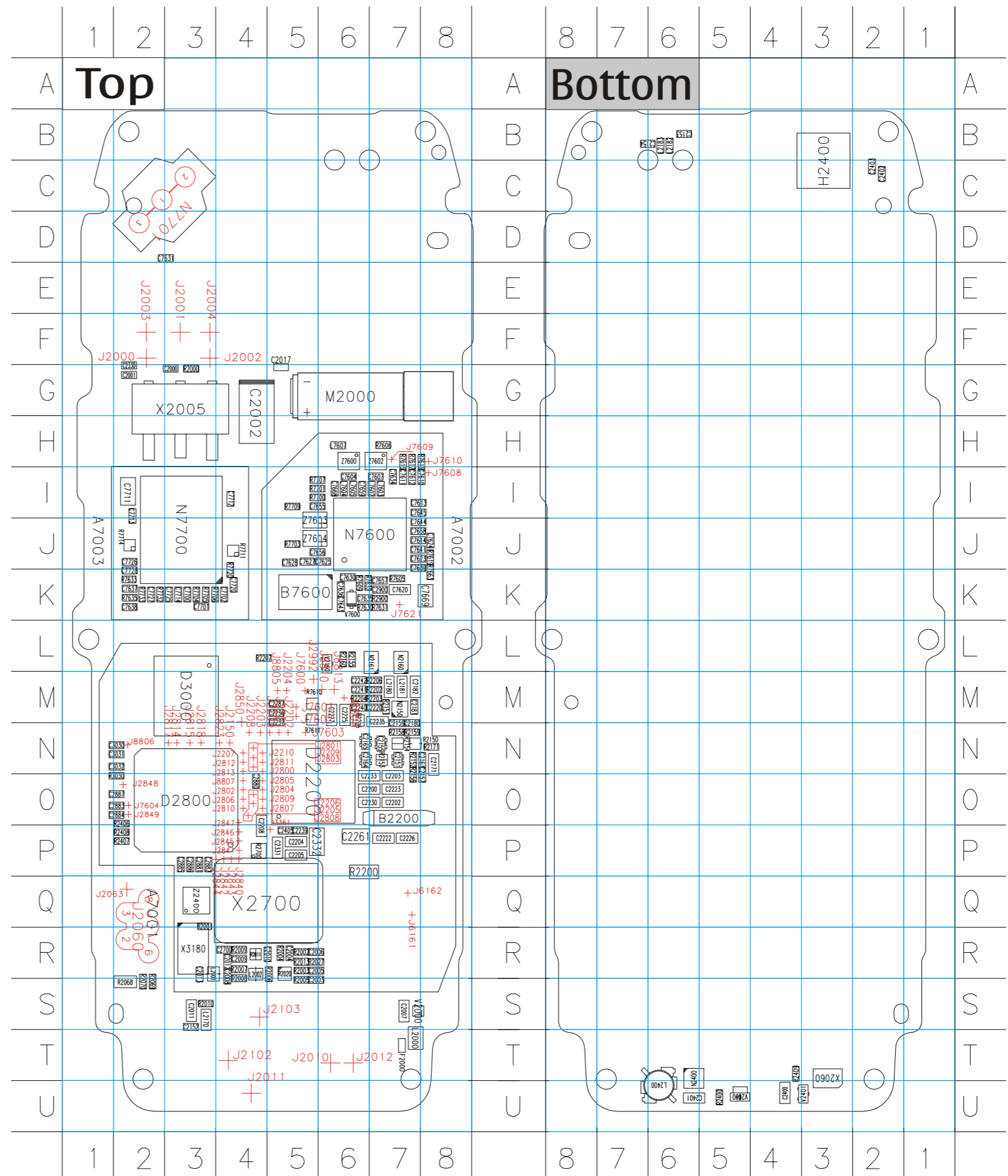








B	C2239	P5	C7644	J7	J2207	N4	J8808	M6	R2154	N7	V		
B2200	07	C2240	M6	C7645	I7	J2208	N4	J8810	M6	R2155	L6	V2000	S7
B7600	K5	C2241	M6	C7655	I5	J2209	N4	J8813	M6	R2156	07	V2160	L6
C	C2242	M6	C7656	J5	J2210	N4	L	R2158	N7	V2400	U5		
C2000	G3	C2261	P6	C7657	K7	J2800	N4	L2000	T7	R2159	N7	V2401	U3
C2001	G2	C2287	M5	C7658	J7	J2801	N4	L2001	R3	R2160	L6	V7600	K6
C2002	G4	C2330	G2	C7659	I6	J2802	04	L2002	R4	R2171	N8	X	
C2003	S5	C2331	P5	C7668	I6	J2803	N4	L2170	S3	R2200	P6	X2005	G3
C2004	R5	C2332	P5	C7669	K8	J2804	04	L2180	M7	R2202	M7	X2060	T3
C2005	R5	C2400	U4	C7700	K3	J2805	04	L2181	M7	R2203	M7	X2700	Q4
C2006	R5	C2401	U6	C7701	K3	J2806	04	L2182	B6	R2204	M6	Z	
C2007	S7	C2402	C2	C7702	K4	J2807	04	L2183	B6	R2205	M6	Z2400	Q3
C2008	R4	C2403	C2	C7711	I2	J2808	04	L2400	U6	R2206	M7	Z7600	H6
C2009	R4	C2405	P5	C7712	I4	J2809	04	L7602	I7	R2207	L4	Z7602	H7
C2010	R5	C2700	R4	C7713	I2	J2810	04	L7603	I7	R2400	U5	Z7603	J5
C2011	S3	C2880	04	C7714	K3	J2811	N4	L7604	I6	R2406	O2	Z7604	J5
C2012	R4	C2881	P3	C7720	K4	J2812	N4	L7605	I6	R2407	P2		
C2013	R3	C2882	P3	C7725	K3	J2813	N4	L7607	H6	R2408	P2		
C2017	G5	C2883	02	C7726	J2	J2814	N3	M	R2409	T4			
C2151	N7	C2884	02	C7727	K2	J2815	N3	M2000	G6	R2700	P4		
C2152	S3	C2885	P3	C7728	K2	J2817	N3	N	R2900	K7			
C2153	B6	C2886	P3	D	J2818	N3	N2150	M7	R3030	O2			
C2154	B7	C2887	02	D2200	O5	J2823	N4	N2160	L7	R7605	K7		
C2155	N6	C2900	K7	D2800	O3	J2840	P4	N2161	L7	R7606	H7		
C2157	O8	C3030	N2	D3000	M3	J2841	P4	N2400	T6	R7609	K6		
C2159	N7	C3031	N2	F	J2842	P4	N7600	J7	R7610	M5			
C2161	N8	C3032	N2	F2000	T7	J2843	P4	N7700	J3	R7611	M5		
C2164	N6	C7604	I6	H	J2844	P4	R	R7615	H8				
C2165	N7	C7607	I7	H2400	C3	J2845	P4	R2000	G3	R7616	H7		
C2171	N8	C7610	I8	J	J2846	P4	R2001	Q3	R7617	H7			
C2180	N7	C7611	I7	J2000	F2	J2847	04	R2002	R5	R7619	J8		
C2181	M7	C7612	I7	J2001	F3	J2848	02	R2003	R5	R7630	K6		
C2182	M7	C7613	I7	J2002	F3	J2849	02	R2004	R5	R7631	K7		
C2200	07	C7614	J7	J2003	F2	J2850	M4	R2005	S5	R7632	K6		
C2202	07	C7620	K7	J2004	F3	J2992	M5	R2006	R5	R7633	K2		
C2203	07	C7623	J7	J2010	T6	J3361	P5	R2007	R4	R7635	K2		
C2204	P5	C7624	J8	J2011	U4	J6161	Q7	R2008	S4	R7663	K8		
C2205	P5	C7625	J6	J2012	T6	J6162	Q7	R2009	R4	R7700	I5		
C2208	P4	C7627	J5	J2060	Q2	J7600	M5	R2010	S3	R7701	I5		
C2220	M7	C7628	J5	J2063	Q2	J7601	M5	R2011	R4	R7703	J5		
C2222	P7	C7630	K6	J2102	T4	J7602	M5	R2013	R5	R7704	K3		
C2223	07	C7631	D3	J2103	S4	J7603	N5	R2020	R5	R7705	K3		
C2225	M6	C7634	I7	J2150	N4	J7604	O2	R2027	R5	R7706	K3		
C2226	P7	C7635	K6	J2200	N5	J7608	I8	R2068	S2	R7707	I5		
C2227	M6	C7636	K6	J2201	N5	J7609	H7	R2069	S2	R7709	I5		
C2230	07	C7637	K2	J2202	N5	J7610	H8	R2070	S2	R7711	J4		
C2233	07	C7638	K2	J2203	N4	J7621	K7	R2150	N7	R7714	J2		
C2235	M7	C7639	J7	J2204	M5	J8805	M5	R2151	M7	R7720	K4		
C2236	M5	C7641	J7	J2205	04	J8806	N2	R2152	N7	R7732	K2		
C2237	M5	C7643	K6	J2206	04	J8807	04	R2153	N7	R7733	K2		



B	C2239	P5	C7643	K6	J2206	O4	J8807	O4	R2070	S2	R7708	J2	
B2200	O7	C2240	M6	C7644	J7	J2207	N4	J8808	M6	R2150	N7	R7720	K4
B7600	K5	C2241	M6	C7645	I7	J2208	N4	J8810	M6	R2151	M7	R7728	K2
C	C2242	M6	C7655	I5	J2209	N4	J8813	M6	R2152	N7	R7732	K2	
C2000	G3	C2261	P6	C7656	J5	J2210	N4	L	R2153	N7	R7733	K2	
C2001	G2	C2287	M5	C7657	K7	J2800	N4	L2000	T7	R2154	N7	V	
C2002	G4	C2330	G2	C7658	J7	J2801	N4	L2001	R3	R2155	L6	V2000	S7
C2003	S5	C2331	P5	C7659	I6	J2802	O4	L2002	R4	R2156	O7	V2160	L6
C2004	R5	C2332	P5	C7668	I6	J2803	N4	L2170	S3	R2158	N7	V2400	U5
C2005	R5	C2400	U4	C7669	K8	J2804	O4	L2180	M7	R2159	N7	V2401	U3
C2006	R5	C2401	U6	C7700	K3	J2805	O4	L2181	M7	R2160	L6	V7600	K6
C2007	S7	C2402	C2	C7701	K3	J2806	O4	L2182	B6	R2171	N8	X	
C2008	R4	C2403	C2	C7702	K4	J2807	O4	L2183	B6	R2200	P6	X2005	G3
C2009	R4	C2405	P5	C7707	I5	J2808	O4	L2400	U6	R2202	M7	X2060	T3
C2010	R5	C2700	R4	C7711	I2	J2809	O4	L7602	I7	R2203	M7	X2700	Q4
C2011	S3	C2880	O4	C7712	I4	J2810	O4	L7603	I7	R2204	M6	Z	
C2012	R4	C2881	P3	C7713	I2	J2811	N4	L7604	I6	R2205	M6	Z2400	Q3
C2013	R3	C2882	P3	C7714	K3	J2812	N4	L7605	I6	R2206	M7	Z7600	H6
C2017	G5	C2883	O2	C7720	K4	J2813	N4	L7607	H6	R2207	L4	Z7602	H7
C2151	N7	C2884	O2	C7725	K3	J2814	N3	L7609	H2	R2400	U5	Z7603	J5
C2152	S3	C2885	P3	C7726	J2	J2815	N3	L7610	H2	R2406	O2	Z7604	J5
C2153	B6	C2886	P3	C7727	K2	J2817	N3	L7617	H6	R2407	P2		
C2154	B7	C2887	O2	D	J2818	N3	L7709	I5	R2408	P2			
C2155	N6	C2900	K7	D2200	O5	J2823	N4	M	R2409	T4			
C2157	O8	C3030	N2	D2800	O3	J2840	P4	M2000	G6	R2700	P4		
C2159	N7	C3031	N2	D3000	M3	J2841	P4	N	R2900	K7			
C2161	N8	C3032	N2	F	J2842	P4	N2150	M7	R3030	O2			
C2164	N6	C7604	I6	F2000	T7	J2843	P4	N2160	L7	R7605	K7		
C2165	N7	C7607	I7	H	J2844	P4	N2161	L7	R7606	H7			
C2171	N8	C7610	I8	H2400	C3	J2845	P4	N2400	T6	R7609	K6		
C2180	N7	C7611	I7	J	J2846	P4	N7600	J7	R7610	M5			
C2181	M7	C7612	I7	J2000	F2	J2847	O4	N7700	J3	R7611	M5		
C2182	M7	C7613	I7	J2001	F3	J2848	O2	R	R7615	H8			
C2200	O7	C7614	J7	J2002	F3	J2849	O2	R2000	G3	R7616	H7		
C2202	O7	C7618	H6	J2003	F2	J2850	M4	R2001	Q3	R7617	H7		
C2203	O7	C7620	K7	J2004	F3	J2992	M5	R2002	R5	R7619	J8		
C2204	P5	C7623	J7	J2010	T6	J3361	P5	R2003	R5	R7630	K6		
C2205	P5	C7624	J8	J2011	U4	J6161	Q7	R2004	R5	R7631	K7		
C2208	P4	C7625	J6	J2012	T6	J6162	Q7	R2005	S5	R7632	K6		
C2220	M7	C7627	J5	J2060	Q2	J7600	M5	R2006	R5	R7633	K2		
C2222	P7	C7628	J5	J2063	Q2	J7601	M5	R2007	R4	R7635	K2		
C2223	O7	C7630	K6	J2102	T4	J7602	M5	R2008	S4	R7663	K8		
C2225	M6	C7632	H2	J2103	S4	J7603	N5	R2009	R4	R7700	I5		
C2226	P7	C7634	I7	J2150	N4	J7604	O2	R2010	S3	R7701	I5		
C2227	M6	C7635	K6	J2200	N5	J7608	I8	R2011	R4	R7702	J4		
C2230	O7	C7636	K6	J2201	N5	J7609	H7	R2013	R5	R7703	J5		
C2233	O7	C7637	K2	J2202	N5	J7610	H8	R2020	R5	R7704	K3		
C2235	M7	C7638	K2	J2203	N4	J7621	K7	R2027	R5	R7705	K3		
C2236	M5	C7639	J7	J2204	M5	J8805	M5	R2068	S2	R7706	K3		
C2237	M5	C7641	J7	J2205	O4	J8806	N2	R2069	S2	R7707	I5		

